

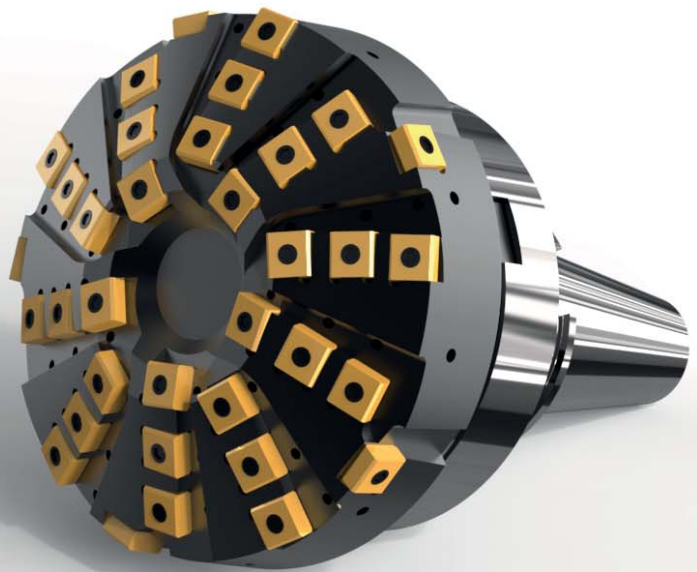

CUS
UTENSILI







The company

CUS Utensili is a family company who designs and manufactures special tools for metal cutting. It is located in Assago, the industrial area in the south of Milan.

Our motto is #CusSolution because in the global market CUS is the ideal partner for any customer looking for effective, innovative and unique solutions. All CUS products add to its high performance a great care of details and of aesthetic reflecting the most typical attitude of the Made in Italy.

The company has been operating in precision mechanics since 1974 and has been growing over the years thanks to the commitment and the determination in understanding customers specific needs and in proposing the most appropriate solutions. It was founded in Milan in the Navigli area and proudly carry on the influences and trends of the of worldwide design capital city.

About CUS Utensili



1 Design

CUS Utensili is made up of a highly qualified design department that works with the best 2D and 3D softwares. It provides cutting tools and solutions that match the ambitions of the customers. The collaboration between our technicians and the customer builds an active and trusting relationship. Listening and sharing informations allows the rapid development of a custom offer drawing. In case of purchase order, the design department will develop the project in every single manufacturing detail.

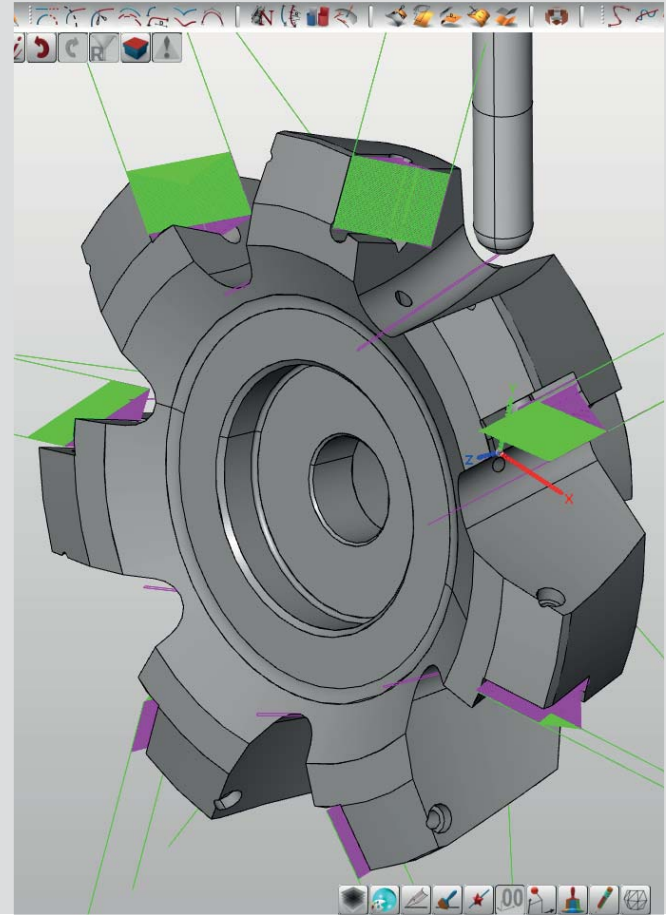

2 Digital Technology

Before manufacturing, each special cutting tool has been virtually realized. A great team work that involves Design Dept. and CAM team works to immediately take advantage of the latest technology. This increase speed and productivity. Furthermore the high reliability and high mechanical precision ensure to the costumers the best quality. Also in case of a re-order.



3 Manufacturing

The manufacturing unit of CUS Utensili is made up of the ultimate generation tool machines. It is able to perform all the challenges in turning, milling and grinding processes. The passion, the involvement and the care for each detail are important aspects of CUS working manners, resulting in the accurate search for the best steel and the most performing treatments and coating. CUS Utensili guarantees both functionality and attractive design of its products.



4 Quality certification

Each special tool manufactured by CUS has got its own Goods ID. Its history is easily traceable. Certificated ISO 9001 since 1997 both for the design and for the manufacturing of special tools, we manage all the different processing phases with extreme care and attention to detail. The traditional control instruments combined with the most innovative ones allow operators to detect step by step all the mechanical and dimensional characteristics of the piece. Inspections are also performed on finished surface. Before reaching the control department, the worked piece has already passed at least 10 checks.

Turning tools

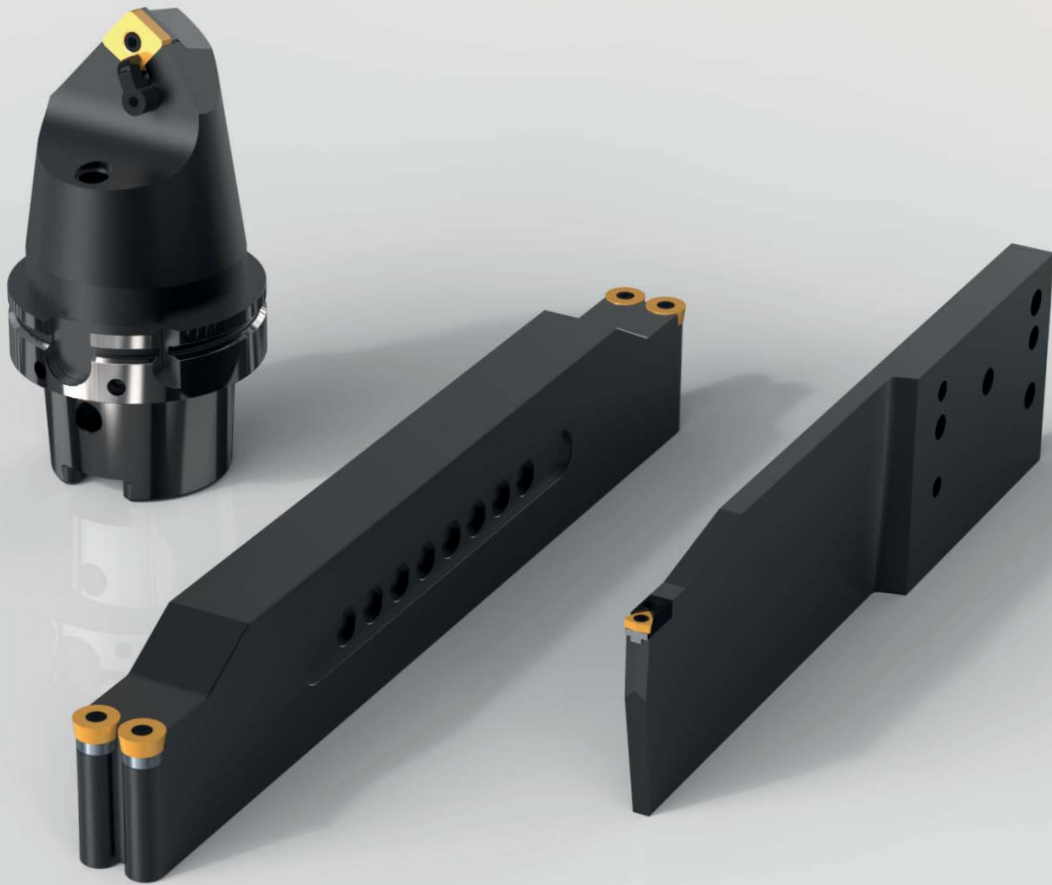

CUS Utensili is able to develop and manufacture tools for all types of turning operations. Our know-how is deep and includes internal turning, external turning, grooving, internal recesses for threading and for chips relief.

Each turning tool is manufactured with the suitable material most indicated at the processing it must perform. It is also equipped with the highest quality components. CUS team usually uses ISO inserts. However it can

also use profiled special inserts, if they are required. We can also offer a profiling service. This happens especially in some specific applications such as: internal and external grooving or threading.

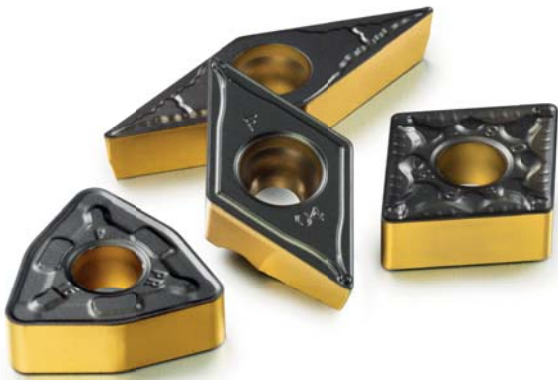

#cussolution

Drilling tools



CUS Utensili has a complete programme of drilling tools.

It develops and manufactures special drills that guarantee high drilling quality and minimum tolerances. CUS special drills help the customers to achieve excellent results for a variety of machining conditions, materials and application types. By using CUS drilling solutions the customers increase profitability and productivity and reduce cycle time and machine wear.



#cussolution

Countersink tools

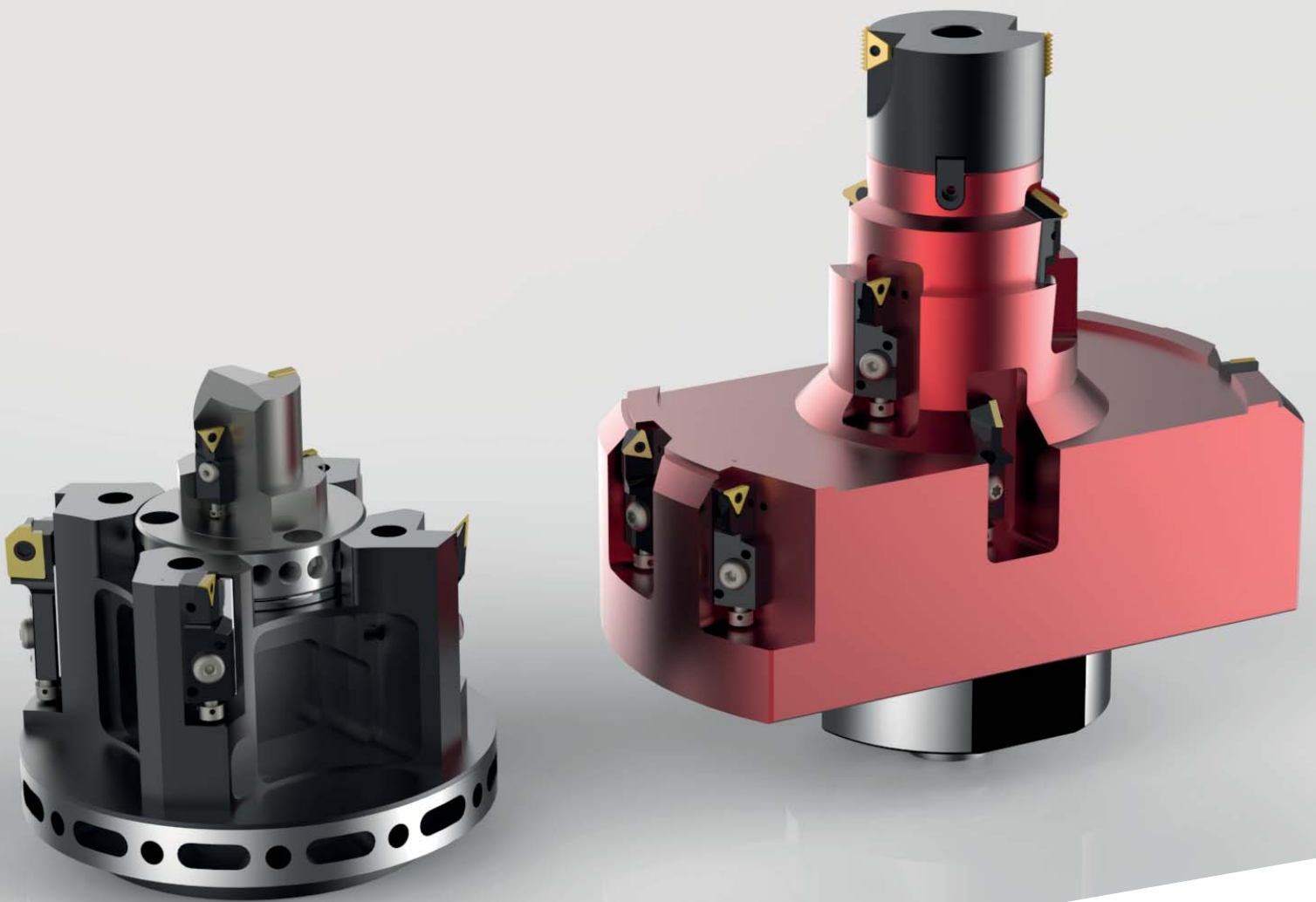

The new generation of CUS countersinks operates both in roughing process and in finishing process. For roughing process they are designed with fixed inserts seats or with adjustable cartridges.

For finishing operations they are usually designed with micro-adjustable units. The result is significant time savings and high productivity.



CusSolution



Reamers



"Blade fix" is the name of CUS single-blade adjustable reamers.

They allow perfect bore geometry and surface finishes. The cutting of the material and the guiding of the reamer in the bore is performed by the blades by means of precision grinding and guide pads located at the best geometric positions. The perfectly aligned adjustment and clamping system for the blade guarantees optimum, play-free seating for the blade and, as result, long tool life.



Milling tools



CUS comprehensive assortment of milling tools provide top-quality performance and reliability.

The cutters offered by the company are able to get the all types of milling works: shoulder milling, face milling, contouring, cut off, slot and groove milling, chamfer milling.

CUS cutters can be equipped with ISO or special inserts.

We have a range of milling tools including T-cutters, disc cutters with fixed and

adjustable seat (slots execution), porcupine cutter, milling cutters with fixed seats or with interchangeable and adjustable cartridges, cutters for roughing etc.

#cussolution



Tool holders

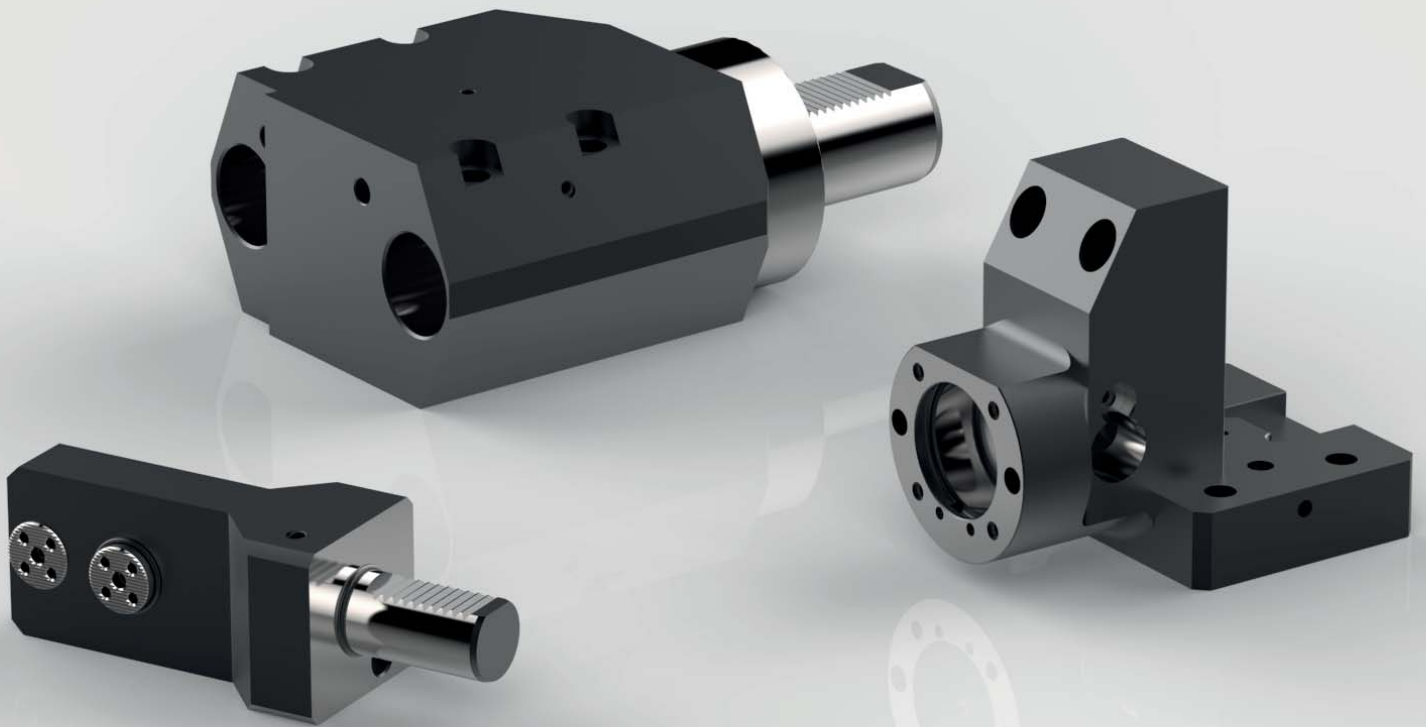

In manufacturing, productivity boils down to how many components can be produced in a certain amount of time. The two main parameters to tune are metal removal rate and machine utilization. To optimize the amount of effective machining time CUS Utensili offers speed clamping system. The company also designs and manufactures tooling solutions with KM shank. All the system are designed with high precision and care.

Solid carbide tools



CUS Utensili offers as a service the design and the manufacturing of special solid carbide tools. In this case minimum batches are required to start the production. Each solid carbide tool is designed to fulfill the demand of high quality, precision and maximum productivity, in this way the customer can get the most out of his machining process.



Application fields

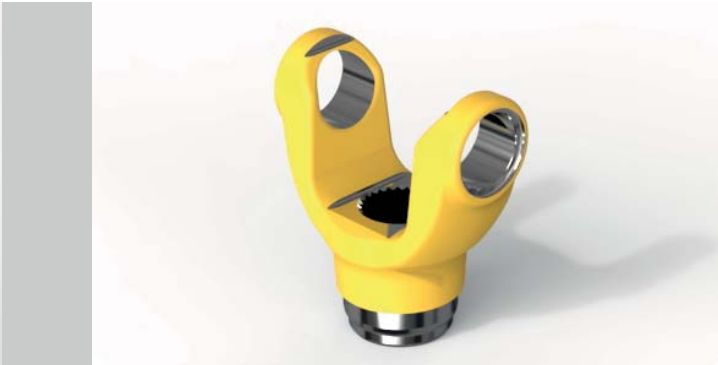
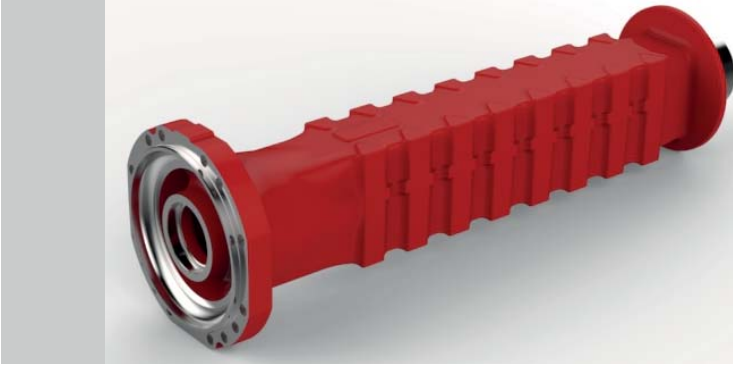

H I C S U N T L E O N E S

Contacts

CUS Utensili srl
Via Concordia, 5
20090 Assago, Mi
Italy

 **+39 02 45 78 43 41**

 **business@cusutensili.com**

 **facebook.com/cusutensili**

 **instagram.com/cusutensili**

www.cusutensili.com



CUS
UTENSILI

Two horizontal bars are positioned below the word 'UTENSILI'. The left bar is green and the right bar is red, mirroring the colors of the Italian flag.